

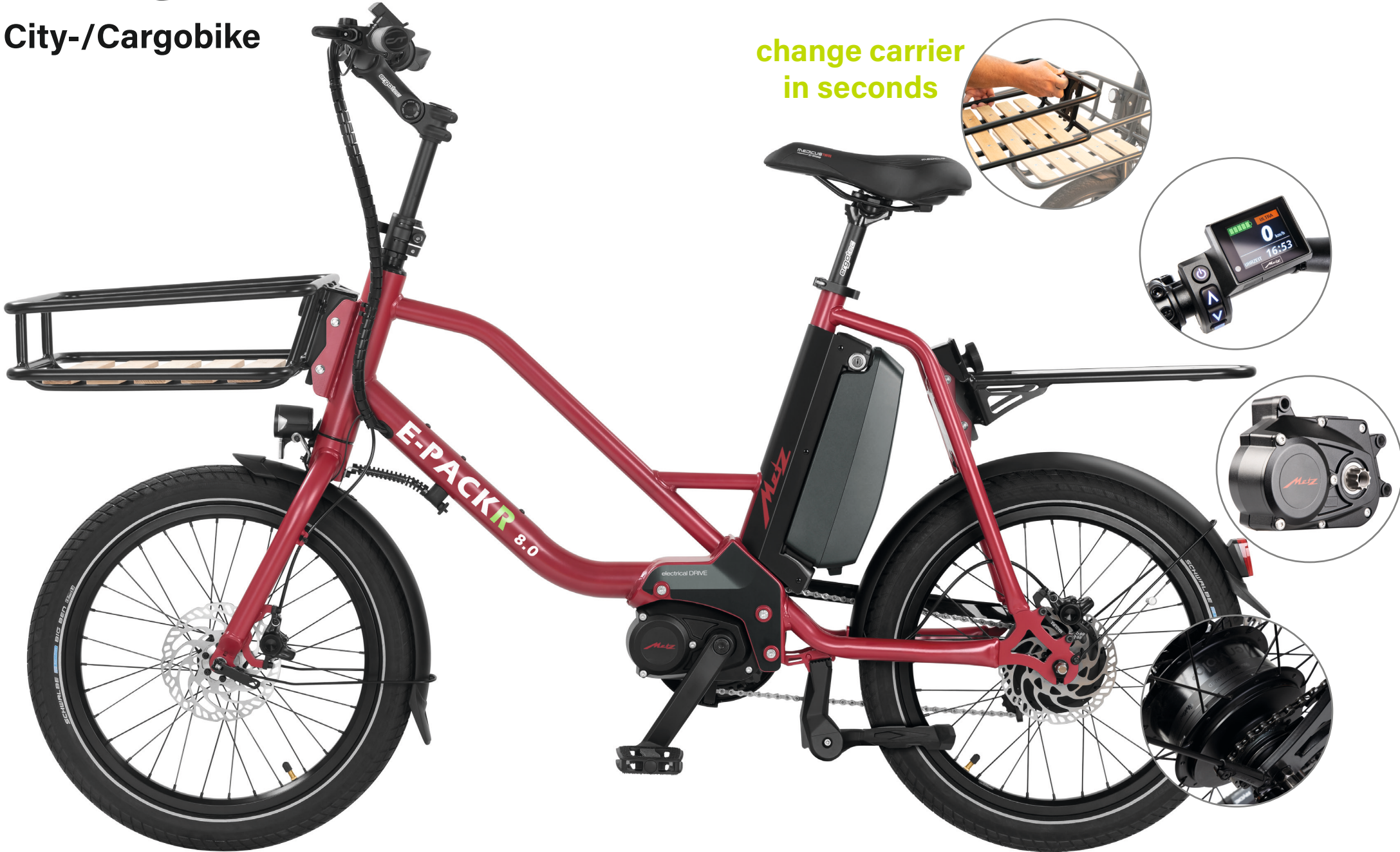

E-PACKR City-/Cargobike

Excellent driving characteristics combined with an efficient motor und compact dimensions. His small storage space and the optimal transportability makes him an ideal companion in all situations. Motor, Display, Frame and the unique MTS-System (Metz quick-change carrier system) are „Made in Germany“.

change carrier
in seconds



■ Features

Models	E-PACKR 8.0	E-PACKR 8.E
Motor type / Torque	Metz G8 / 75 Nm	Metz G8 / 85 Nm
Gear system	Shimano Alfine 8	enviolo HD
Range with eco mode	Real * 100 km/62 mls	Real * 95 km/59 mls
Battery (removable)	Lithium ion 500 Wh	
Max. support	up to 25 km/h ; 15,5 mls/h (DIN EN 15194)	
Frame	chrome molybdenum steel 25CrMo4	
Total weight	approx. 28 kg (incl. battery / no carriers)	
MTS (Metz carrier system)	front 20 kg, rear 30 kg durable	
Maximum weight allowed	180 kg (incl. driver & load)	
Tyre type / -size	Schwalbe Big Ben 20"	
Brake system	Magura hydraulic disc brake	
Stand	Ergotec double-leg kick stand	
Lighting	LED headlight / -backlight	
Display	TFT-colourdisplay (readable in sunlight)	
Colours	black (RAL9011) , red (RAL3032) , white (RAL9003)	

Own bike frame construction & development
Own electric motor development & production
Own bike assembly & bike engineering



Metz — always first class.

Our products are „Made in Germany“

Traditionally - made with conviction. All this shows our new E-Bike drive system by Metz, impresses with its compact dimensions and low weight with best performance values. A High-Performance motor, a clear and intuitive display and at least a long-range battery were developed with the recipe for success by Metz.



Subject to modifications and errors. Images similar. 02/22

■ Our Models

E-PACKR 8.0



Motor / Torque	Metz G8 / 75 Nm
Gear System	Shimano Alfine 8
MTS (Metz-Träger-System) (Carrier-System by Metz)	Max. Load: front 20 kg, rear 30 kg

E-PACKR 8.E



Motor / Torque	Metz G8 / 85 Nm
Gear System	enviolo HD
MTS (Metz-Träger-System) (Carrier-System by Metz)	Max. Load: front 20 kg, rear 30 kg

■ Accessories



Child Seat
Mounting on rear carrier



Side Bag Holder
Mounting on rear carrier



Dog Basket
Max. 8 kg with protective grid



Shopping Basket
Basket with KLIckfix adapter

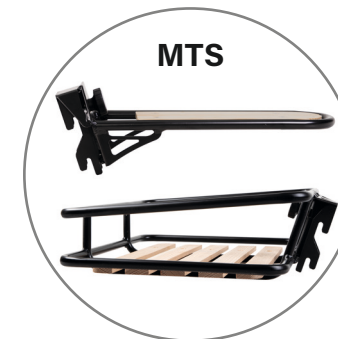

Metz-Carrier-System
Metal/Wooden Basket & Carrier



MTS Adapter
KLIckfix compatible

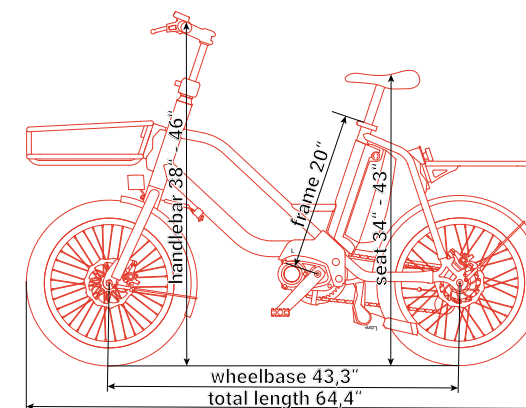

Please do not hesitate to contact us!

Metz mobility GmbH
Flugplatzstr. 100
90768 Fürth



Tel. +49 911 97536-90
email: sales@metz-mobility.de
www.metz-mobility.de

